

Part Number : 201-1103-C35-P0

Description : Ultra Tiny BNC Right Angle Plug, Crimp Type for UHD-0.8/3.7, Belden 1505A Cable

Drawing :

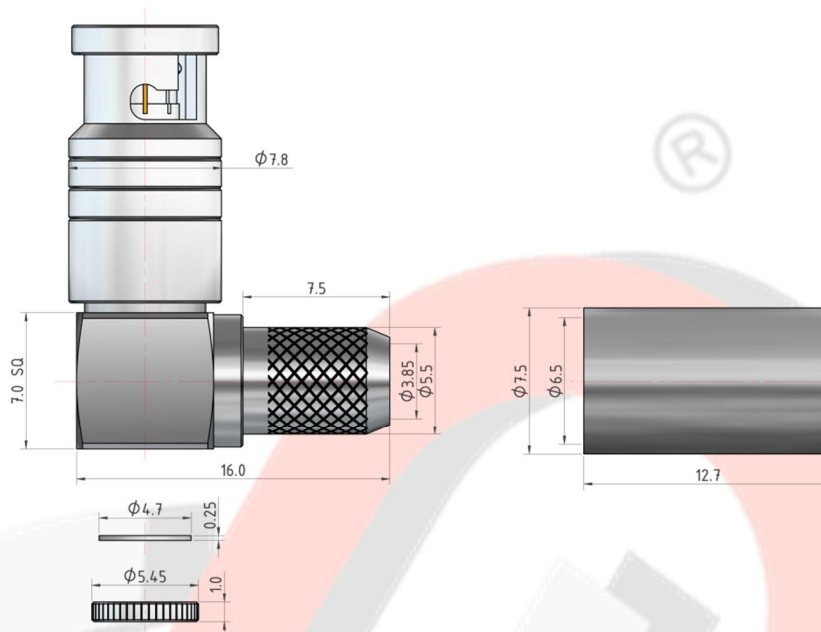

Materials and Finishes

Shell	Brass	Nickel Plating
Body	Brass	Nickel Plating
Insulator	PTFE	None
Inner Contact	BeCu	Gold Plating
Ferrule	Brass	Nickel Plating
Spacer	Delrin	None
Cap	Brass	Nickel Plating

Technical Data

Electrical Data:

Impedance	75 Ω
Frequency Range	DC to 12 GHz
Voltage Rating	500 V rms. (Depending on Cable)
Insulator Resistance	$\geq 5 \text{ G}\Omega$
Dielectric Withstanding Voltage	1000 V rms.
Contact Resistance	Inner Contact : $\leq 3 \text{ m}\Omega$ Outer Contact : $\leq 2.5 \text{ m}\Omega$

Mechanical Data :

Mating Bayonet Coupling

Environmental Data :

Temperature Range	-65 to 165 °C
Corrosion (Salt Spray)	MIL-STD-202, Method 101, Cond. C
Thermal Shock	MIL-STD-202, Method 107, Cond. B
Mechanical	MIL-STD-202, Method 213, Cond. I
Vibration	MIL-STD-202, Method 204, Cond. D
2011/65/EU (RoHS)	Compliant with Exemption 6(c)
REACH SVHC	Compliant (Based on The Latest SVHC Candidate List)

Misc. Information (Recommended)

Cable Stripping Dimensions (Conductor/Dielectric/Braid)	3.5 / 2.1 / 7.5 mm	
Assembling Method	Inner Contact	Solder
	Ferrule	Crimp (HEX .255")
Recommended Hand Tool	Ferrule	HT-909N
Cable Group	UHD-0.8/3.7, Belden 1505A	
Weight	7.56g	
Packaging	Single Pack	
Location of Manufacture	Taiwan	

Revisions



ISS	Description	DATE
A	Original	2017/07/04