

Part Number : 012-2112-C06-WP3

Description : SMA Bulkhead w/O-Ring Jack, Crimp Type for RG316 (Waterproof)

Drawing :

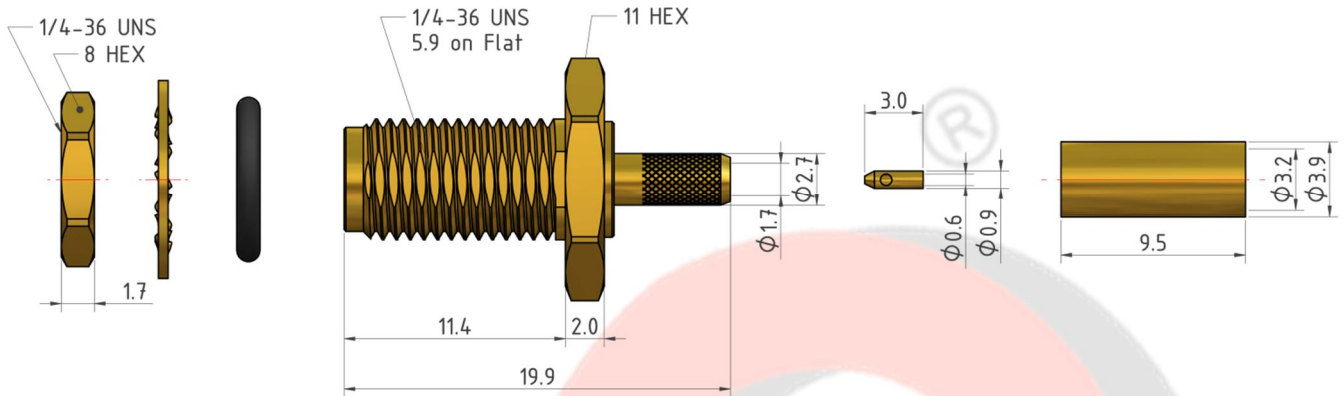

## Materials and Finishes

Body	Brass	Gold Plating
Insulator	PTFE	None
Inner Contact	P. Bronze	Gold Plating
Center Contact	Brass	Gold Plating
Ferrule	Brass	Gold Plating
O-Ring	NBR	Black
Lock Washer	Brass	Gold Plating
Nut	Brass	Gold Plating

## Technical Data

Electrical Data:

Impedance	50 $\Omega$
Frequency Range	DC to 12.4 GHz
Voltage Rating	500 V rms. (Depending on Cable)
Insulator Resistance	$\geq 5 \text{ G}\Omega$
Dielectric Withstanding Voltage	1000 V rms.
Contact Resistance	Inner Contact : $\leq 3 \text{ m}\Omega$ Outer Contact : $\leq 2.5 \text{ m}\Omega$

Mechanical Data :

Mating 1/4-36 UNS Screw-on Coupling

Recommended Mating Torque      7.1 ~ 9.7 lbs  
 Coupling Nut Retention Force       $\geq$  60.7 lbs

Environmental Data :

Temperature Range                      -65 to 165 °C  
 Corrosion (Salt Spray)                MIL-STD-202, Method 101, Cond. B  
 Thermal Shock                            MIL-STD-202, Method 107, Cond. B  
 Mechanical                                MIL-STD-202, Method 213, Cond. I  
 Vibration                                    MIL-STD-202, Method 204, Cond. D  
 2011/65/EU (RoHS)                      Compliant with Exemption 6(c)  
 REACH SVHC                                Compliant (Based on The Latest SVHC Candidate List)

**Misc. Information** (Recommended)

Cable Stripping Dimensions (Conductor/Dielectric/Braid)	2.5 / 1.5 / 6.5 mm	
Assembling Method	Inner Contact	Solder
	Ferrule	Crimp ( HEX .133" )
Recommended Hand Tool	Inner Contact	N/A
	Ferrule	HT-909M
Cable Group	RG-174 / RG-188 / RG-316 / LMR-100 / 1.5D-2V	
Weight	4.33 g	
Packaging	Single Pack	
Location of Manufacture	Taiwan	