

Part Number : 011-2138-C05-P6

Description : SMA Straight Plug, Crimp Type for RG178 Cable

Drawing :

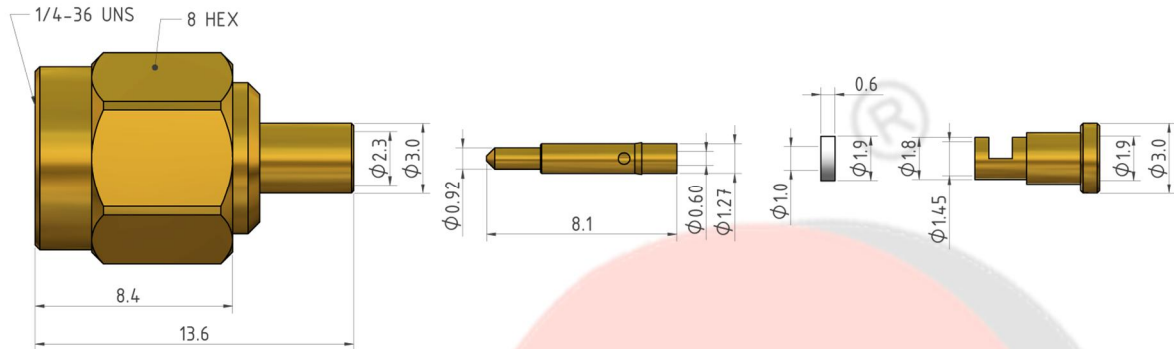

Materials and Finishes

Body	Brass	Gold Plating
Insulator	PTFE	None
Inner Contact	Brass	30u" Gold Plating
Bushing	PTFE	None
Inner Tube	Brass	Gold Plating

Technical Data

Electrical Data:

Impedance	50 Ω
Frequency Range	DC to 12.4 GHz
Voltage Rating	500 V rms. (Depending on Cable)
Insulator Resistance	$\geq 5 \text{ G}\Omega$
Dielectric Withstanding Voltage	1000 V rms.
Contact Resistance	Inner Contact : $\leq 3 \text{ m}\Omega$ Outer Contact : $\leq 2.5 \text{ m}\Omega$

Mechanical Data :

Mating	1/4-36 UNS Screw-on Coupling
Recommended Mating Torque	7.1 ~ 9.7 lbs
Coupling Nut Retention Force	$\geq 60.7 \text{ lbs}$

Environmental Data :

Temperature Range	-65 to 165 °C
Corrosion (Salt Spray)	MIL-STD-202, Method 101, Cond. B
Thermal Shock	MIL-STD-202, Method 107, Cond. B
Mechanical	MIL-STD-202, Method 213, Cond. I
Vibration	MIL-STD-202, Method 204, Cond. D
2011/65/EU (RoHS)	Compliant with Exemption 6(c)
REACH SVHC	Compliant (Based on The Latest SVHC Candidate List)

Misc. Information (Recommended)

Cable Stripping Dimensions (Conductor/Dielectric/Braid)	2.5 / 0.7 / 2.6 mm	
Assembling Method	Inner Contact	Solder or Crimp (SQ .036" or HEX .043")
	Mandril	Crimp (HEX .100")
Recommended Hand Tool	Inner Contact	N/A
	Mandril	HT-909M
Cable Group	RG178 Cable	
Weight	2.78 g	
Packaging	Single Pack	
Location of Manufacture	Taiwan	