

Part Number : 211-1101-C32-P0

Description : 12G SDI BNC Straight Plug, Crimp Type for B1855A; B4855R; UHD-0.6/2.6

Drawing :

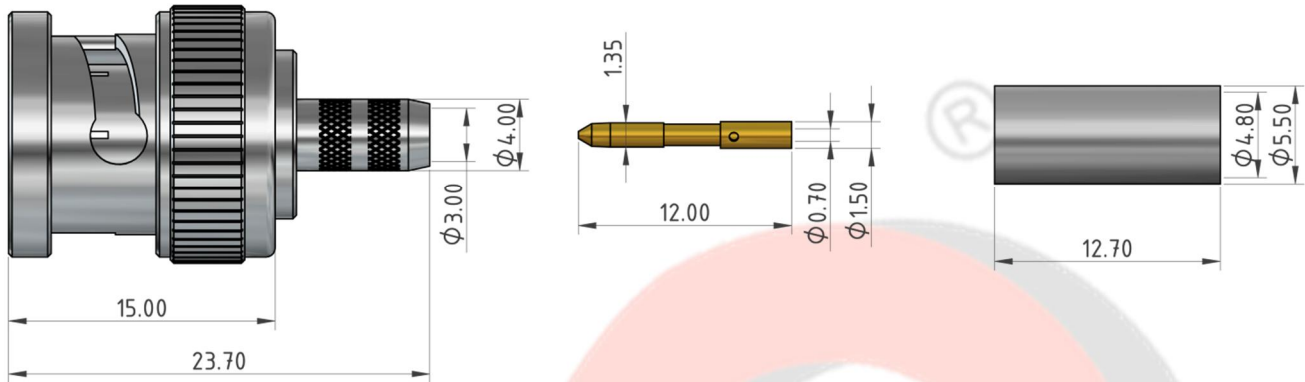

### Materials and Finishes

Shell	Brass	Nickel Plating
Body	Brass	Nickel Plating
Insulator	PTFE	None
Inner Contact	Brass	Gold Plating
Ferrule	Brass	Nickel Plating

### Technical Data

Electrical Data:

Impedance	75 $\Omega$
Frequency Range	DC to 12 GHz
Voltage Rating	500 V rms. (Depending on Cable)
Insulator Resistance	$\geq 5 \text{ G}\Omega$
Dielectric Withstanding Voltage	1500 V rms.
Contact Resistance	Inner Contact : $\leq 1.5 \text{ m}\Omega$ Outer Contact : $\leq 1 \text{ m}\Omega$

Mechanical Data :

Mating	Bayonet Coupling
Engagement Force :	0.6~2.5 lbs

**Environmental Data :**

Temperature Range	-65 to 165 °C
Corrosion (Salt Spray)	MIL-STD-202, Method 101, Cond. C
Thermal Shock	MIL-STD-202, Method 107, Cond. B
Mechanical	MIL-STD-202, Method 213, Cond. I
Vibration	MIL-STD-202, Method 204, Cond. D
2011/65/EU (RoHS)	Compliant with Exemption 6(c)
REACH SVHC	Compliant (Based on The Latest SVHC Candidate List)

**Misc. Information** (Recommended)

Cable Stripping Dimensions (Conductor/Dielectric/Braid)	3.5 / 3.0 / 7.5 mm	
Assembling Method	Inner Contact	Solder or Crimp ( SQ .042" or HEX .051" )
	Ferrule	Crimp ( HEX .187" )
Recommended Hand Tool	Inner Contact	HT-301G2
	Ferrule	HT-801V
Cable Group	B1855A; B4855R; UHD-0.6/2.6	
Weight	9.86g	
Packaging	Single Pack	
Location of Manufacture	Taiwan	