

Part Number : 091-1101-C32

Description : 1.0/2.3 S/T Quick-Lock Plug, Single Crimp Type for B1855A; B4855R; UHD-0.6/2.6

Drawing :

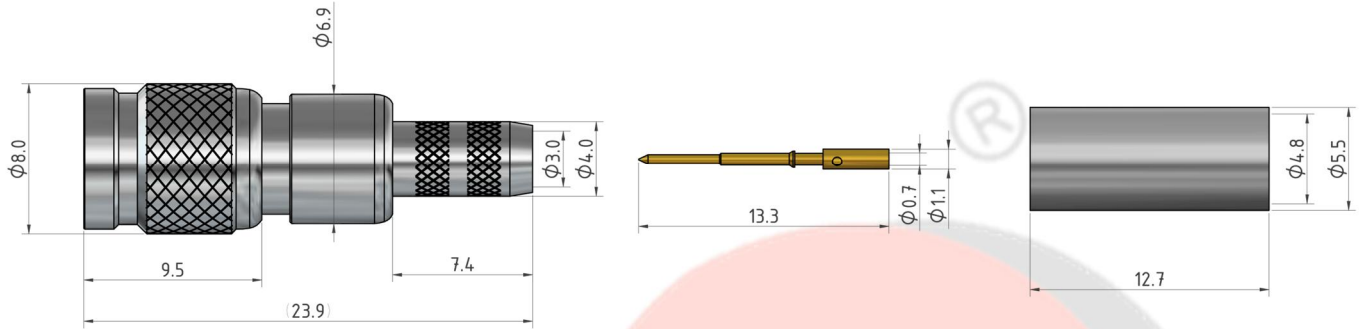

### Materials and Finishes

Shell	Brass	Nickel Plating
Outer Contact	P. Bronze	Gold Plating
Body	Brass	Nickel Plating
Insulator	PTFE	None
Inner Contact	Brass	Gold Plating
Ferrule	Brass	Nickel Plating

### Technical Data

Electrical Data:

Impedance	75 $\Omega$
Frequency Range	DC to 6 GHz
Voltage Rating	500 V rms. (Depending on Cable)
Insulator Resistance	$\geq 5 \text{ G}\Omega$
Dielectric Withstanding Voltage	1000 V rms.
Contact Resistance	Inner Contact : $\leq 3 \text{ m}\Omega$ Outer Contact : $\leq 2.5 \text{ m}\Omega$

Mechanical Data :

Mating	Quick-Lock Coupling.
Cable Retention Force:	$\geq 20 \text{ lbs.}$

Environmental Data :

Temperature Range	-45 to 85 °C
Corrosion (Salt Spray)	MIL-STD-202, Method 101, Cond. C
Thermal Shock	MIL-STD-202, Method 107, Cond. B
Mechanical	MIL-STD-202, Method 213, Cond. B
Vibration	MIL-STD-202, Method 204, Cond. A
2011/65/EU (RoHS)	Compliant with Exemption 6(c)
REACH SVHC	Compliant (Based on The Latest SVHC Candidate List)

### Misc. Information (Recommended)

Cable Stripping Dimensions (Conductor/Dielectric/Braid)	3.0 / 1.5 / 7.5 mm	
Assembling Method	Inner Contact	Solder
	Ferrule	Crimp ( HEX .184" )
Recommended Hand Tool	Inner Contact	N/A
	Ferrule	HT-801V
Cable Group	B1855A; B4855R; UHD-0.6/2.6	
Weight	4.89g	
Packaging	Single Pack	
Location of Manufacture	Taiwan	

## Revisions

ISS	Description	DATE
A	Original	2017/07/04

